

***Nikon***

**Stereoscopic Zoom Microscope**

**SMZ1000 / SMZ800**

**Instructions**

Thank you for purchasing the Nikon product.

This instruction manual is written for the users of Nikon Stereoscopic Zoom Microscopes.

To ensure correct usage, read this manual carefully before operating the instrument.

- It is prohibited to reproduce or transmit this manual in part or whole without Nikon's expressed permission.
- The contents of this manual are subject to change without notice.
- Although every effort has been made to ensure the accuracy of this manual, if you note any points that are unclear or incorrect, contact your nearest Nikon representative.
- Some of the products described in this manual may not be included in the set you have purchased.

### Warning/Caution Symbols Used in This Manual

Though Nikon products are designed to provide you with the utmost safety during use, incorrect usage or disregard of the instructions may cause personal injury or property damage. For your own safety, read the instruction manual carefully and thoroughly before using the product. Do not discard this manual. Always keep it near the product for easy reference.

Inside this instruction manual, safety instructions are indicated with the symbols shown below. Be sure to follow the instructions marked with these symbols for your safety.

<b>Symbol</b>	<b>Meaning</b>
 <b>WARNING</b>	Disregarding instructions marked with this symbol may lead to death or serious injury.
 <b>CAUTION</b>	Disregarding instructions marked with this symbol may lead to injury or property damage.





## WARNING

### 1. Intended use of this product

This product is intended only for microscopy. Do not use it for any other purpose.

### 2. Do not disassemble

Disassembly may result in damage to the instrument. Never disassemble any part except as described in this operation manual. Contact your Nikon representative if you notice any malfunction of this instrument.

### 3. Check the input voltage

When using an illuminator, check that the input voltage displayed on the power supply of the illuminator matches the operating voltage. Contact your Nikon representative if the displayed voltage does not match the operating voltage. Use of an improperly matched illuminator may result in damage to equipment.

### 4. Power cord

Always turn the power switch off and unplug the power cord when replacing the lamp of an illuminator as failure to do so may result in electric shock or equipment damage.

### 5. Heat from the light source

When using an illuminator, do not place cloth or paper or highly flammable materials, such as gasoline, benzene, thinner or alcohol, near the lamp as there is a danger of fire.

- Always use lamps that are of the specified rating only. For the lamp rating, please refer to the operation manual.
- Always turn the power switch off and unplug the power cord when replacing the lamp of a illuminator as failure to do so may result in electric shock or equipment damage.



## CAUTION

### 1. Caution when replacing lamps

The lamp and the surrounding area become very hot during and immediately after using the illuminator. Be careful not to burn yourself. In addition, when replacing a lamp be sure the lamp has cooled sufficiently.

### 2. Check the light source

Always use lamps that are of the specified rating only. Use of a lamp having a different specification may result in damage to equipment. For the lamp rating, please refer to the operation manual.

## 1. Installation location

Note the following points when installing the stereoscopic microscope.

- Install the microscope in a location with the temperature between 0° and 40°C, and humidity of less than 80%. If installed in a hot and humid location, mold may form on the lenses or condensation may occur inside, resulting in reduced performance or damage to the microscope.
- Do not install the microscope in a location subject to direct sunlight.
- Install the microscope in a location that is not subject to vibration.
- Install the microscope in a location that is free from dust and dirt.

## 2. Handle the microscope carefully

The stereoscopic microscope is a precision optical instrument. Handle it carefully and do not subject it to impact. Shock from impact during transportation or operation as well as forcible operations may cause damage to the instrument.

## 3. Cleaning the lenses

Do not let dust, fingerprints, etc. to get on the lenses. Dirt on the lenses will adversely affect the view of the image. If any lenses become dirty, clean them as described below.

- Use an air blower to blow dust away. If this does not suffice, brush away the dust with a soft brush or gently wipe it away with a piece of gauze.
- Only if the lenses become dirty with fingerprints or grease stains, slightly dampen a piece of soft, clean cotton cloth with absolute alcohol (ethyl alcohol or methyl alcohol) and gently wipe away the dirt. Do not use the same part of the cloth more than once.
- Since absolute alcohol is highly flammable, be careful in handling it so that it does not ignite.
- Observe the manufacturer's handling instructions when handling absolute alcohol.

## 4. Cleaning painted or plastic parts

Use of silicon cloth is recommended when cleaning painted parts, plastic parts and printed parts. If such a part becomes excessively dirty, wipe it gently with gauze dampened in a mild detergent solution. Do not use organic solvents (such as alcohol, ether, or paint thinner) as this may result in deformation of the part or remove of lettering.

## 5. Storage

Store the microscope in a location with low humidity where mold is unlikely to form. Do not store the microscope in a location subject to direct sunlight or high temperature and humidity. During storage, place a plastic cover over the equipment to prevent dust accumulation.

## 6. Regular inspections

Regular inspections are recommended in order to maintain peak performance. Please consult your Nikon representative for details about regular inspections.

<b>Warning/Caution Symbols Used in This Manual</b> .....	1
<b>Be sure to always follow these guidelines.</b> .....	2
△ <b>WARNING</b> .....	2
△ <b>CAUTION</b> .....	3
<b>I Nomenclature</b> .....	8
<b>II Assembly</b> .....	12
<b>III Usage</b> .....	15
<b>1 Preparations For Observation</b> .....	15
1. Adjust the torque of the focus knob .....	15
2. Adjust the interpupillary distance .....	15
3. Adjust the diopter .....	16
<b>2 Focusing</b> .....	16
1. Check the working distance .....	16
2. Focus on the sample .....	16
<b>3 Zoom</b> .....	17
1. Change the zooming magnification .....	17
<b>4 If You Cannot Focus On The Sample Though The Zooming         Body Is At The Highest Position.</b> .....	18
<b>IV Using Accessories</b> .....	19
<b>1 Reticles</b> .....	19
<b>2 Eyepiece Tube</b> .....	19
1. P-BTL low eye-level eyepiece tube .....	19
2. P-BERG tilted eyepiece tube .....	20
<b>3 P-IER Eyelevel Riser</b> .....	20
<b>4 Plan 1X ERGO Objective</b> .....	21
<b>5 SM-S4L 4 X 4 Stage L</b> .....	22
<b>V Illuminator</b> .....	23
<b>1 Halogen Illuminators</b> .....	23
1. Lamp .....	24
2. Attaching G-LS to the stand [C-PS & C-PSC] .....	25
3. Arm for halogen illuminators .....	25
4. Power supplies .....	27

5. Lighting area adjustment [G-LS] .....	29
6. Attaching filters [C-DSLS] .....	29
<b>2 P-ICI2 Coaxial Episcopic Illuminator</b> .....	29
<b>VI Photomicrographic and TV-related Accessories</b> .....	32
1. Photomicrographic magnification .....	33
2. Attaching the beam splitter .....	33
3. Photo reticles .....	34
4. Photomicrography procedure .....	34

Table 1: Total Magnification and Real Field .....	36
---	----

Table 2: Observable Sample Heights [mm] .....	38
---	----

# I Nomenclature

The figures on p.8 & 9 show a SMZ1000 zooming body, with P-BT binocular eyepiece tube, C-W 10X eyepieces, Plan Apo 1X objective, C-FMC focusing mount, and C-PS160 plain stand.

**Diopter ring**

Refer to "Adjust the diopter" on p.16.

**Eyepieces**

10X, 15X, 20X and 30X eyepieces are available.

**Eyepiece tube clamp screw**

**Zooming body clamp screw**

Fixes the zooming body to the focusing mount.

**Zooming body**

Outside diameter of the part to be mounted the focusing mount:  $\phi 78$

**Objective**

Plan 1X, Achro 0.5X, Plan 1X ERGO, Plan Apo 0.5X, Plan Apo 1X, ED Plan 1.5X and ED Plan 2X objectives are available. HR Plan Apo series objectives for SMZ1500 can be used also, but the magnification in this case becomes 1.25 times the magnification indicated on the objective itself. Refer to Table 1 on p.36.

**Groove for mounting accessories**

Holds the Fluorescent ring illuminator, Fiber optic ring illuminator and the like. Outside diameter:  $\phi 60$

**Stage plate clamp screw**

Fixes the stage plate to the stand base.

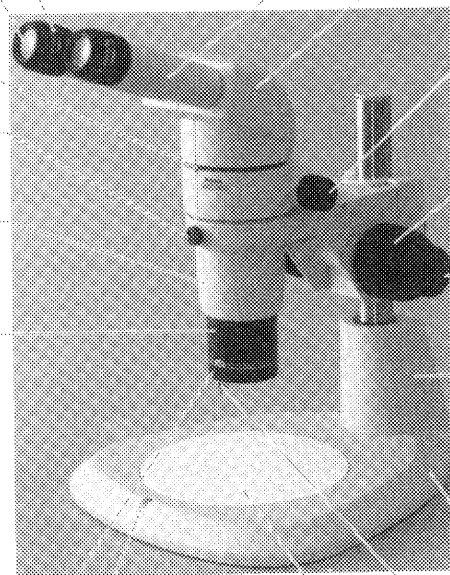

**Eyepiece sleeve**

**P-BT Binocular eyepiece tube**

P-BTL low eye-level eyepiece tube and P-BERG tilted eyepiece tube are also available.

**Zooming knob**

Changes the magnification of the sample image. Refer to "Zoom" on p.17.

**Coarse focus knob**

Refer to "Focusing" on p.16.

**Fine focus knob**

Refer to "Focusing" on p.16.

**Stand**

**C-PS160 Stand base**

Various stands are available.

**Screw for mounting accessories**

Holds the 1/4 lambda plate and the like. The screw on the inside diameter: M55 x 0.75

**Stage plate**

The black or the white side can be chosen according to the sample.

**C-FMC Focusing mount**

**Screw hole for mounting an Epi-arm for halogen illuminator**

Located on both sides of the focusing mount. Holds the G-EIA flexible arm or Epi-arm.

**Screw hole for mounting accessories**

Located on both sides of the stand base. M5

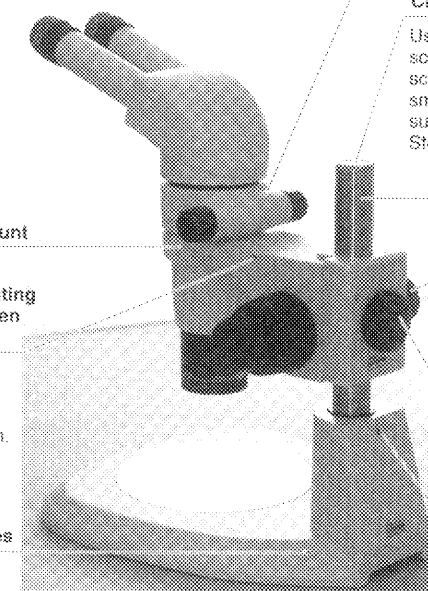

**Zooming knob clicks ON/OFF screw (inside)**

Refer to "ON/OFF of the Zooming Knob Clicks" on p.17.

**Clamp tool**

Used for the stage plate clamp screw, eyepiece tube clamp screw, etc. Same size as the small hexagonal wrench supplied with the zooming body. Stored in the top of the pillar.

**Pillar**

**Torque adjustment ring (Innermost ring)**

Adjusts the torque of the focus knob. (Refer to "Adjust the focus knob torque" on p.15.)

**Focusing mount clamp screw**

Fixes the focusing mount to the pillar.

**Pillar clamp screw (Inside)**

The illustrations on p.10 & 11 show a SMZ800 zooming body, with P-BT binocular eyepiece tube, C-W 10X eyepieces, Plan 1X objective, and C-PS plain focusing stand.

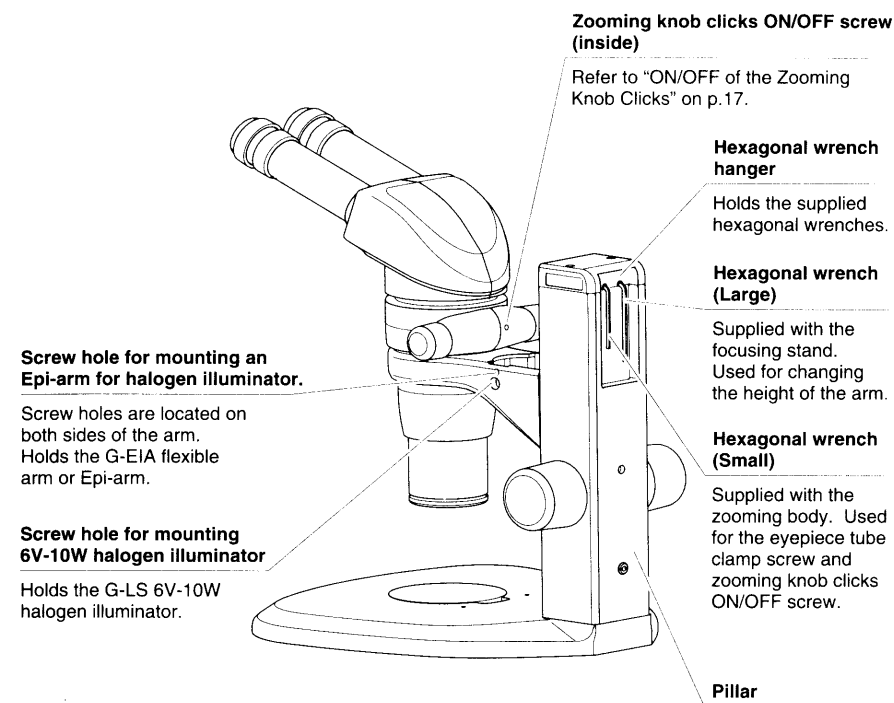
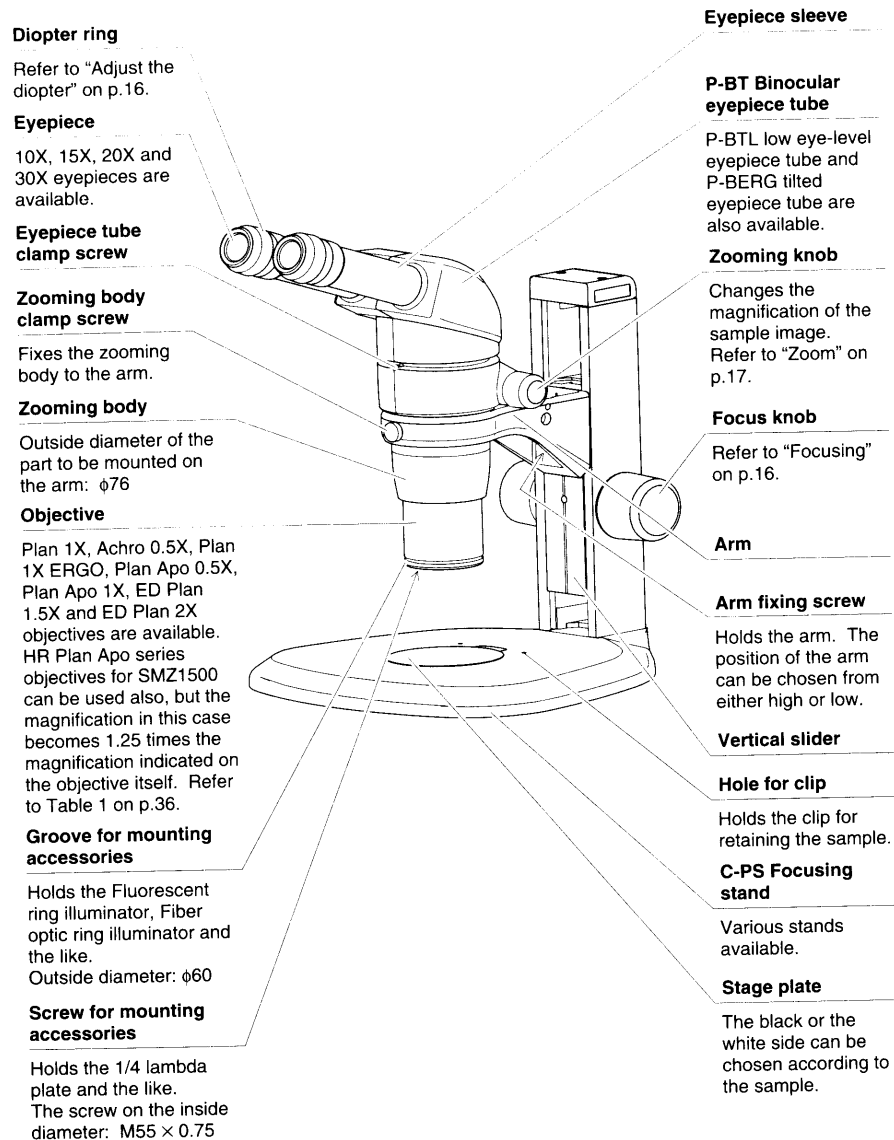

## II Assembly

II

-  • An equipment model name in the bold-faced brackets [ ] indicates that the following description is exclusively for that model.

### 1 [C-PS160] Attach the pillar to the stand.

Insert the pillar straight into the stand with the groove of the pillar located down as far as the pillar reaches to the bottom. Clamp the pillar using the clamp tool.

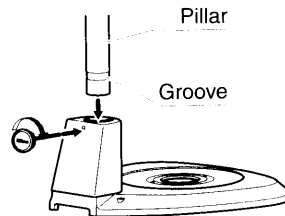

### 2 Place the stand on the level surface.

### 3 Mount the stage plate.

[C-PS160]

Fit the stage plate into the stand base. Tighten the stage plate clamp screw using the clamp tool to fix the stage plate.

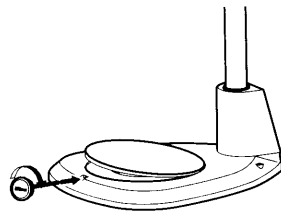

[C-PS & C-PSC]

Fit the stage plate into the stand base while pushing it against the rim in the direction shown by the arrow in the illustration.

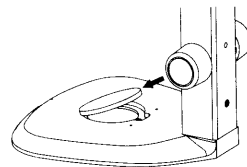

### 4 [C-PS160] Fix the C-FMC focusing mount to the pillar.

Face the focusing mount to the front and tighten the focusing mount clamp screw.

*Note) When fixing the focusing mount to the upper part of the pillar, securely tighten the clamp screw so as not to fall the focusing mount.*

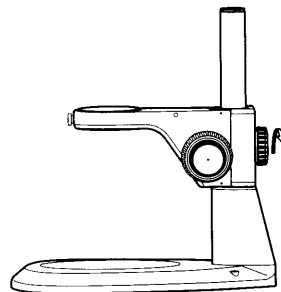

### 5 [C-PS & C-PSC] The stand arm can be lowered. (If you do not need to lower the arm, jump to step 6.)

Use the hexagonal wrench (large - supplied with the focusing stand) to loosen the arm fixing screw. Reattach the arm using the screw hole at the lower side of the vertical slider. The arm will become 55 mm lower than its original position. Before tightening the screw, make sure that the two pins on the arm fit in the grooves on the vertical slider.

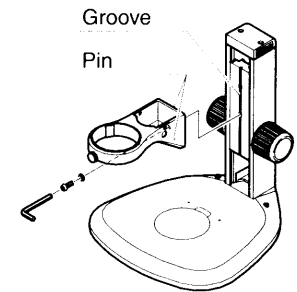

### 6 Mount the zooming body.

Lightly tighten the zooming body clamp screw to hold the zooming body on the focusing mount or arm.

*Note) Do not over-tighten the zooming body clamp screw since it may cause damage to the instrument.*

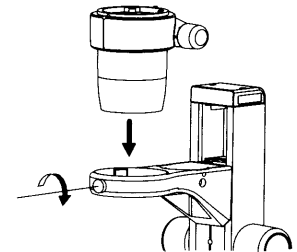

### 7 Screw the objective into the bottom of the zooming body.

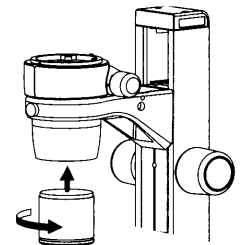

### 8 Mount the eyepiece tube.

Align the groove on the eyepiece tube with the positioning pin on the zooming body, push the eyepiece tube toward the back to attach. Tighten it to the zooming body using the supplied hexagonal wrench (small) or the clamp tool supplied with the C-PS160.

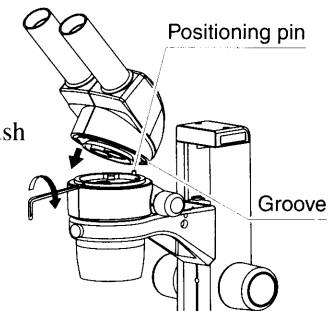

**9 Insert the eyepieces into the eyepiece sleeves.**

Be sure that it is inserted all the way until it touches the end of the sleeve.

*Note) When inserting the eyepiece, hold the rubber cover of the eyepiece. Holding the diopter ring causes a failure. Especially, be careful with the 10X eyepieces because their rubber covers obstruct the view of the sleeve end.*

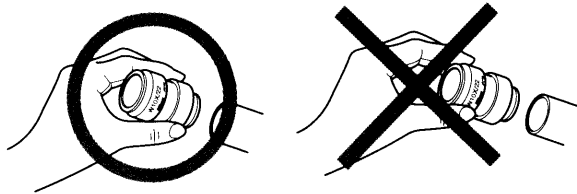

**10 The hexagonal wrenches and clamp tool can be stored in the pillar of the stand.**

Refer to the figures on p.9 and p.11.

**1 Preparations For Observation**

**1 Adjust the torque of the focus knob.**

Adjust the torque of the focus knob so as not to fall down the zooming body on its own weight.

**[C-FMC]**

Turn the torque adjustment ring using the clamp tool. Turning the ring in the direction of the arrow indicated on the side surface of the focusing mount will increase the torque.

*Note) • Do not twist the left and right focus knobs.*

- *Do not turn the knob beyond its turning limit.*
- *Do not turn the fine focus knob while holding the coarse focus knob or vice versa. Otherwise, the damage to the instrument will result.*

Increasing the torque.

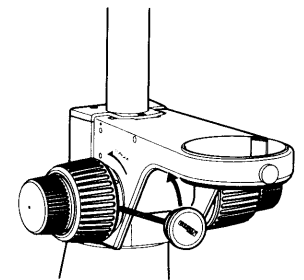

Increasing the torque.

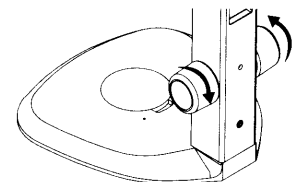

(To reduce the torque, turn the knob in the direction opposite to the arrow.)

**[C-PS and C-PSC]**

Rotating the left and right focus knobs in the opposite direction as shown in the illustration will increase the torque.

**2 Adjust the interpupillary distance.**

This adjustment should be performed every time the observer is changed since the interpupillary distance differs between individuals. Adjust the interpupillary distance so that the view field for each eye is merged into one. Move while holding each sleeve with both hands.

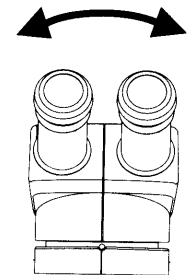

**3 Adjust the diopter.**

This adjustment should be performed every time the observer is changed since the eyesight differs between individuals.

- 1 Turn the diopter rings on both eyepieces to set them at the 0 position (match the 0 line with the index line).
- 2 Turn the zooming knob to the highest magnification. Focus on the sample using the focus knob. (Refer to "Focusing".)
- 3 Turn the zooming knob to the lowest magnification. Peering through the left eyepiece with the left eye, focus on the sample using the diopter ring on the left eyepiece. Then, peer through the right eyepiece with your right eye and focus on the sample using the diopter ring on the right eyepiece.
- 4 Repeat steps 2 and 3 until the image is kept focused even though the zooming magnification is changed. This adjustment ensures sharp image throughout the zooming range.

**2 Focusing****1 Check the working distance.**

The distance between the focus plane and the bottom of the objective is called the working distance. Focusing is easier if beforehand the distance between the specimen and the bottom of the objective is set to the working distance. The working distance differs depending on the objective being used. Please refer to Table 1 on p.36.

**2 Focus on the sample.**

Turning the focus knob moves the zooming body up and down and brings focus on the sample.

**[C-FMC]**

Using the fine focus knob will permit the delicate focusing. Especially, it is effective for the high magnification observation.

**3 Zoom****1 Change the zooming magnification.**

Turning the zooming knobs on the left and right side of the zooming body will change the magnification of the sample image.

**■ Total Magnification**

The zooming knob has the indication of the zooming magnification. The total magnification can be found by multiplying the magnification of the objective times that of the eyepieces.

*Note) When the HR Plan Apo series objective for the SMZ1500 is used, the total magnification will be obtained by multiplying by 1.25.*

**■ ON/OFF of the Zooming Knob Clicks**

The clicks on the zooming knob can be eliminated.

- 1 Insert the supplied hexagonal wrench (small) or the clamp tool supplied with the C-PS160 into the screw hole on the rear of the zooming body.
- 2 Turning the inside screw in the direction opposite to the arrow eliminates the clicks (OFF). Turning the same screw in the direction of the arrow puts on back the clicks (ON).

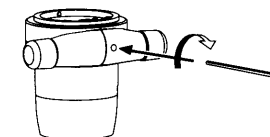

## 4 If You Cannot Focus On The Sample Though The Zooming Body Is At The Highest Position.

When you use the 0.5X objective or observe a tall sample, you may not be able to focus on the sample though turning the focus knob to raise the zooming body to its highest position.

### [C-PS160]

Exchange the pillar for the C-EP extension pillar available on order. Attach the C-EP extension pillar to the stand in the same manner as for the standard pillar. (Hold the side having the groove downward. Refer to item 1. on p.12.) Put the stopper ring on the pillar and then the focusing mount. Tighten the focusing mount clamp screw.

*Note)* Contact the bottom surface of the focusing mount with the stopper ring and securely tighten each clamp screw.

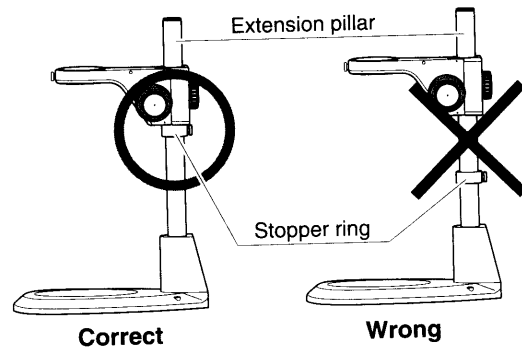

### [C-PS & C-PSC]

Use the C-ER auxiliary adapter available as an option. (This adapter can't be used for the SMZ1000.)

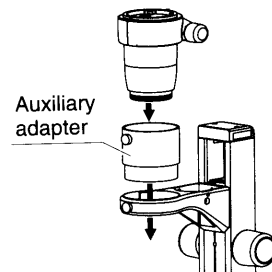

- Refer to the Table 2 on p.38 for the sample heights which may be viewed.

## IV Using Accessories

### 1 Reticles

Your reticles may be attached to the eyepiece. Once remove the field ring (or lens room of the 20X and 30X) from the eyepiece. Attach the reticle with its pattern surface facing down to the eyepiece and reattach the field ring (or lens room).

- Refer to the Table 1 on p.36 for the size of the reticle which may be attached.

*Note)* The 20X and 30X eyepieces adopt the internal focusing system, and the primary image has the magnification. Use the reticle with 1.3X pattern for 20X eyepiece, and with 1.4X pattern for 30X eyepiece.

A reticle with cross hairs, scaled cross hairs, or photographic mask is available on order for 10X eyepiece.

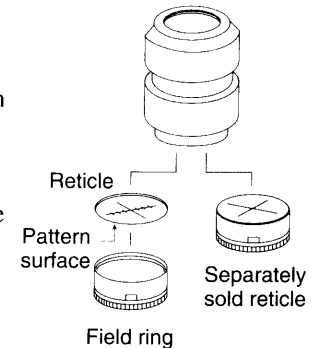

### 2 Eyepiece Tube

#### 1 P-BTL low eye-level eyepiece tube

When using a beam splitter or coaxial episcopic illuminator, it is possible to lower the eye level (eye level during observation) by using this eyepiece tube in place of the binocular eyepiece tube.

The installation procedure for this eyepiece tube is the same as for the P-BT binocular eyepiece tube.

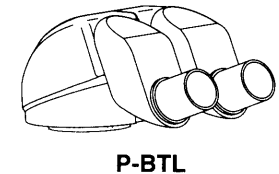

P-BTL

**2 P-BERG tilted eyepiece tube**

This eyepiece tube allows the angle of the eyepiece sleeve to be continuously adjusted as desired by the observer.

It is also possible to change the eye level by rotating the interpupillary distance adjuster (shown in gray in the illustration) 180°.

The installation procedure for this eyepiece tube is the same as for the P-BT binocular eyepiece tube.

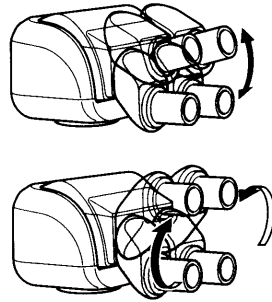
**P-BERG****CAUTION**

Be careful not to put your fingers between the interpupillary distance adjuster and the lower part of the eyepiece tube when adjusting the angle of the sleeve.

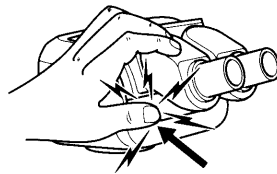
**3 P-IER Eyelevel Riser**

When the eye level is too low, it is possible to raise the eye level by 25 mm by attaching a P-IER Eyelevel riser between the zooming body and the eyepiece tube. It is possible to use up to three Eyelevel risers at once.

Avoid using the four or more Eyelevel risers at once or using the other intermediate tube together such as a beam splitter or coaxial episcopic illuminator. It may cause the vignetting around the image periphery.

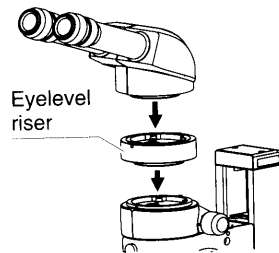
**4 Plan 1X ERGO Objective**

Using the Plan 1X ERGO objective allows you to continuously change the eye level through a 40 mm range while maintaining a constant working distance (50 mm).

- 1** Rotate the upper knurled ring on the Plan 1X ERGO objective to attach it to the zooming body.
- 2** Rotate the focus knobs on the focusing stand to raise or lower the microscope to set to the height best suited for viewing.
- 3** Rotate the lower knurled ring to focus on the specimen. Use the microscope as usual after setting the eye level.

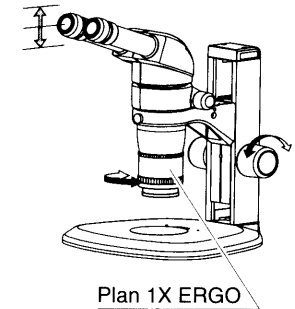

*Note) When attaching to the SMZ1000, vignetting will occur in the lateral direction of the viewfield at the high eye level with 1X or lower zoom magnification.*

## 5 SM-S4L 4 X 4 Stage L

SM-S4L 4 X 4 stage L may be attached by using the C-4SA stage adapter. In this case, use the C-ER auxiliary adapter or C-EP extension pillar because the position of the sample will become higher. (Refer to "4. If you cannot focus on the sample though the zooming body is at the highest position.")

- 1 Remove the stage plate from the stand base, and attach the C-4SA stage adapter in place using the fixing screws supplied with the adapter.
- 2 Sufficiently loosen the stage clamp screw of the SM-S4L 4 X 4 stage L. Fit and mount the stage onto the stage adapter with the side equipped with the stage clamp screw facing front. Tighten the stage clamp screw.

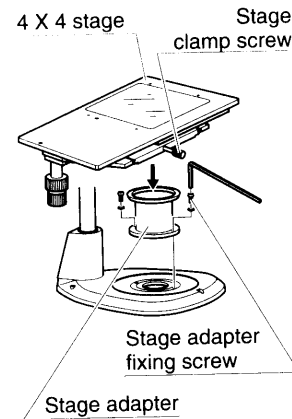

## 1 Halogen Illuminators

There are two illuminators available: the G-LS of 6V 10W and the C-DSLS of 6V 20W.

*Note) These illuminators are not adequate to observe the sample having a high reflective surface. Use the P-ICI2 Coaxial Episcopic Illuminator on p.29 for this purpose.*

### G-LS (6V10W)

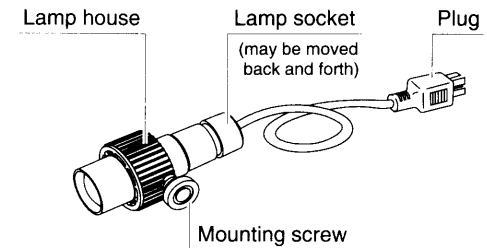

### C-DSLS (6V20W)

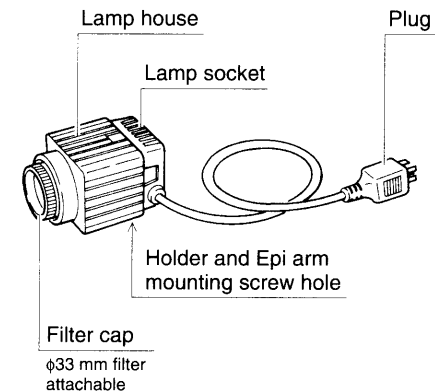

**1 Lamp**



**CAUTION** The lamp and the surrounding area become very hot during and immediately after using the illuminator. Be careful not to burn yourself. In addition, be sure the lamp has cooled sufficiently before replacing a lamp.

Pull the lamp socket from the lamp house and insert the lamp straight into the socket as far as it will go. Only use halogen lamps of the specified rating. Next, attach the lamp socket to the lamp house.

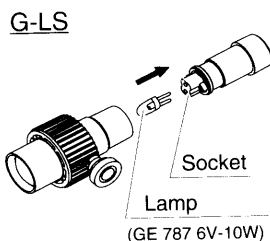

**C-DSLS**

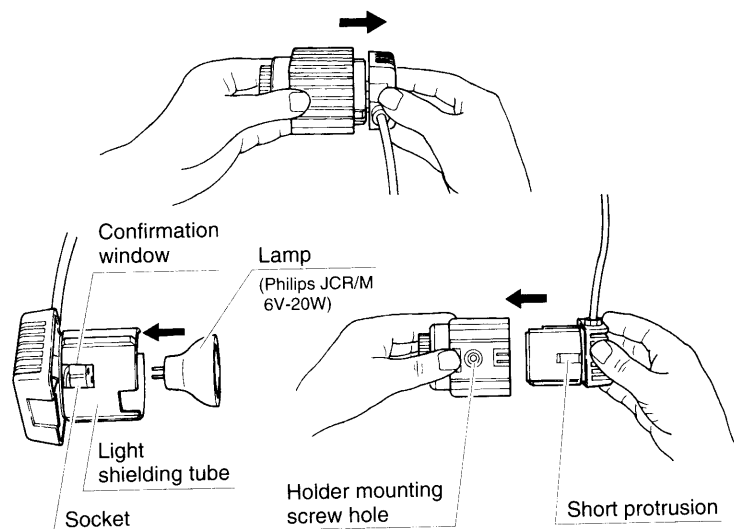

*Note) Do not touch the glass part of a lamp with your bare hands as your skin may burn and stick to the lamp, possibly reducing its level of light output or causing damage to the lamp. When replacing a*

*lamp, handle it through a piece of cloth or through its packaging until replacement is complete. If you get fingerprints on the lamp, wipe gently with a piece of clean cloth dampened with alcohol.*

**2 Attaching G-LS to the stand [C-PS & C-PSC]**

Set so that the protrusion on the lamp house aligns with the inside of the screw hole on the arm of the stand (screw hole for mounting 6V10W halogen illuminator) and secure it in place from the outside of the arm using the mounting screw.

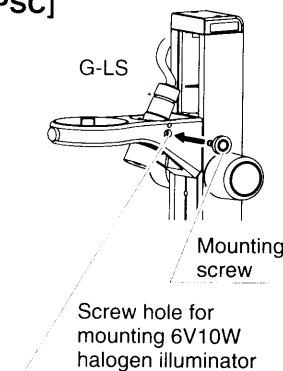

**3 Arm for halogen illuminators**

It is possible to freely adjust the direction of illumination by using a special arm.

**1 G-EIA flexible arm [G-LS]**

Set so that the protrusion on the lamp house aligns with the inside of the hole in the holder of the flexible arm and secure it in place from the outside of the holder using the mounting screw.

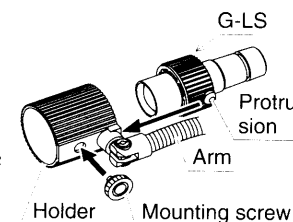

Secure by screwing the mounting screw supplied with the arm into the arm mounting screw hole in the stand (screw hole for mounting an Epi-arm).

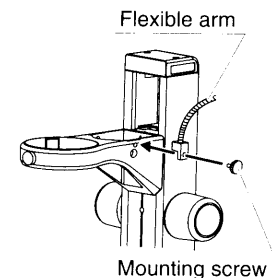

**Power Supply XN (only for regions with 100/120 V power)**

Input rating	Power supply for 100V regions only: 100 V AC, 50/60 Hz, 30 W Power supply for 120V regions only: 120 V AC, 50/60 Hz, 30 W
Output rating	3-6 V AC, 3.3 A
Fuse rating	250 V, 1 A

**Power Supply TN-PSE30 (only for regions with 230 V power)**

Input rating	230V AC, 50/60Hz, 0.3A
Voltage fluctuation	±10%
Output rating	AC 6V 5A
Internal fuse	Fast acting type, F1A/250V, 5.2 × 20 mm
Operating environment	Altitude: 2000 m max. Temperature: 0° - 40°C (indoor use only) Relative humidity: 85% max. (no condensation) Pollution level: Degree 2 Installation: Category 2
Storage environment	Temperature: -20° - 60°C Relative humidity: 90% max. (no condensation)
Protection class	Class 1
Power cord	Use only the following power supply cord. Using the wrong power cord could result in danger or fire. The protection Class 1 equipment should be connected to PE (protective earth) terminal. • For 220-240V AC area Approved according to EU/EN standards, 3 conductor grounding Type H05VV-F, 3 m long maximum, rated at 250V AC minimum.

**5 Lighting area adjustment [G-LS]**

It is possible to adjust the lighting area by moving the lamp socket back and forth. Adjust the lighting area to allow easy viewing.

**6 Attaching filters [C-DSLS]**

Rotate and remove the filter cap at the end of the lamp house and insert a filter. Use filters that have a diameter of 33 mm and a width of 1.5 ~ 2 mm.

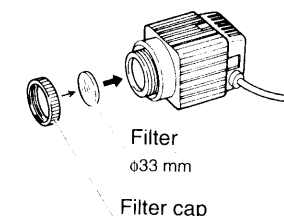

**2 P-ICI2 Coaxial Episcopic Illuminator**

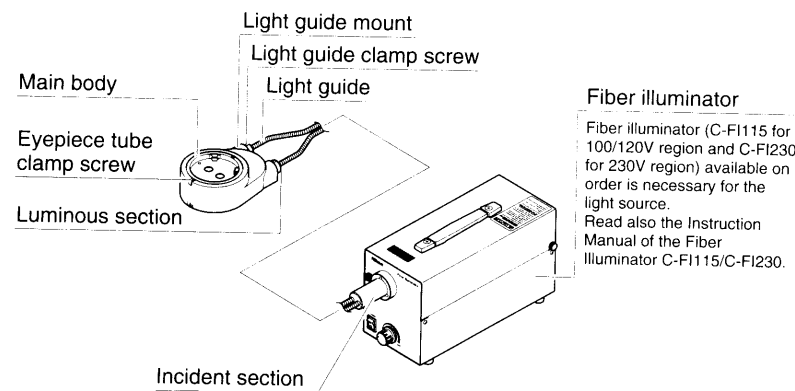

Magnification of the P-ICI2 Coaxial Episcopic Illuminator is 1.5X. Total magnification is obtained by multiplying 1.5 by the total magnification of the basic set of the microscope.

*Note) Usable magnification for the P-ICI2 Coaxial Episcopic Illuminator is restricted. Use the magnification within the range shown in the right*

Objective	Zooming magnification
Acro 0.5X	3X or higher
Plan 1X	1.5X or higher
Plan 1X ERGO	1.5X or higher
Plan Apo 0.5X	4X or higher
Plan Apo 1X	2X or higher
ED Plan 1.5X	2X or higher
ED Plan 2X	Not usable
HR Plan Apo 0.5X	2.5X or higher
HR Plan Apo 1X	2.5X or higher
HR Plan Apo 1.6X	Not usable

table. If the magnification out of the specified range is used, uneven illumination will occur or the seeing of the sample image will be degraded.

- 1 Mount the P-ICI2 onto the zooming body aligning the groove on the bottom of the P-ICI2 main body with the positioning pin on the zooming body while tilting the P-ICI2 toward the rear. Tighten the eyepiece tube clamp screw.

Note) When the other intermediate tube such as a beam splitter is used together, attach it on the P-ICI2.

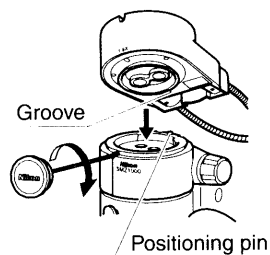

- 2 Screw in the 1/4 lambda plate to the end of the objective. When the C-FIR ring fiber light guide is used together, use the other 1/4 lambda plate separately available for ring fiber illuminator.

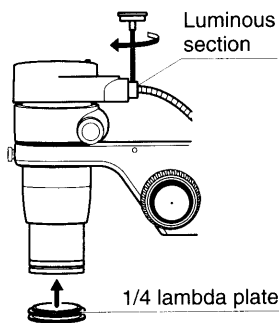

- 3 Insert the incident section of the light guide into the light guide mount of the fiber illuminator and tighten the clamp screw. Insert the luminous section of the light guide into the light guide mount of the P-ICI2 and tighten the clamp screw.

- 4 The optical axis of the 1/4 lambda plate is at the 45° position from the red dot. Brightness is the maximum when the red dot is positioned at the front and switches from bright to dark by each 45° position. Adjust the plate to the position where the brightness and contrast are best suited for the observation.

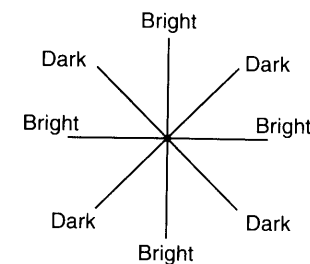
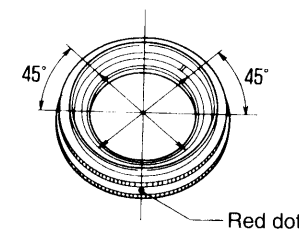

- 5 Insert the filter P-ICI33 NCB14 into the fiber illuminator to improve the color reproducibility when taking a photomicrograph. Refer to the instruction manual of Fiber Illuminator.

It is possible to photograph images or display them on a TV monitor by attaching a beam splitter between the zooming body and the eyepiece tube.

There are two beam splitters available: the S P-IBSS with one port and the D P-IBSD with two ports.

Read also the instruction manual of the instrument such as a photomicrographic equipment or TV camera to be used.

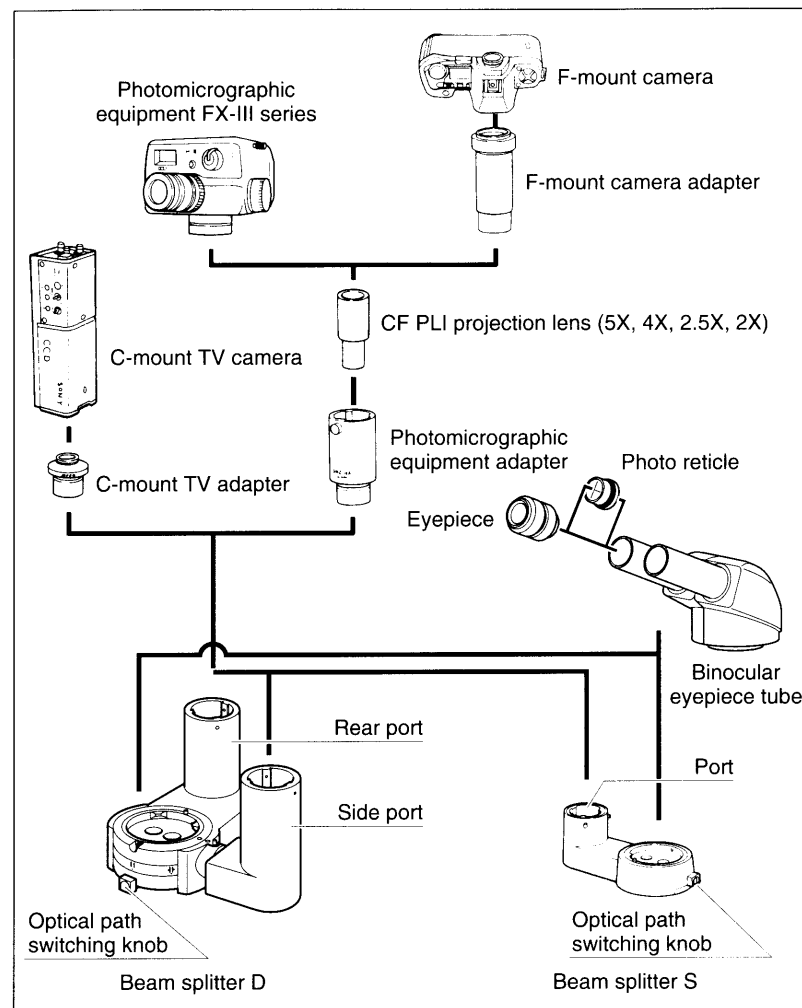

## 1 Photomicrographic magnification

Photomicrographic magnification = (PLI projection lens magnification) × (Zoom magnification) × (Objective magnification)

- When the P-ICI2 Coaxial Episcopic Illuminator is used:  
Photomicrographic magnification = (PLI projection lens magnification) × (Zoom magnification) × (Objective magnification) × 1.5

- When the HR Plan Apo series objective is used:  
Photomicrographic magnification = (PLI projection lens magnification) × (Zoom magnification) × (Objective magnification) × 1.25

## 2 Attaching the beam splitter

Mount the beam splitter onto the zooming body aligning the groove on the bottom of the beam splitter with the positioning pin on the zooming body while tilting the beam splitter toward the rear. Tighten the eyepiece tube clamp screw.

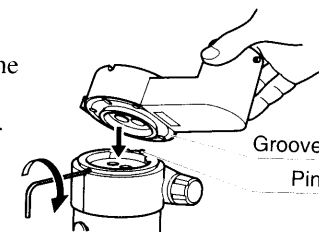

**[P-IBSS]** Mount it so as to position the port at either the left or right.

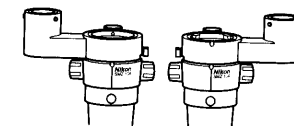

P-IBSS Port location

**[P-IBSD]** 1) Mount it so as to position the rear port at the rear.

2) Attach the side port to the beam splitter main body with the positioning pin on the side port fitted into the groove on the beam splitter main body. Tighten the side port clamp screw.

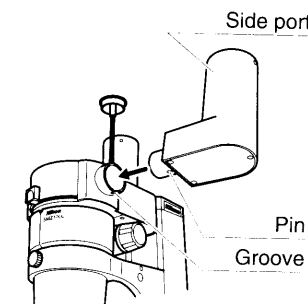

P-IBSD Attaching side port

**3 Photo reticles**

Attaching the C-FP photo reticle to the C-W10X eyepiece permits you to make focusing for photomicrography through the eyepiece. Select the correct frame indicating the area being photographed according to the magnification of the PLI projection lens. For more accurate focusing and photographing area, use the finder of the photomicrographic equipment.

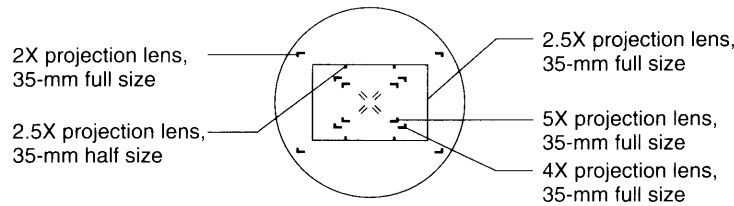

**4 Photomicrography procedure**

**1 Switching the optical path**

**[P-IBSS]** Set the optical path switching knob to PHOTO/BINO.

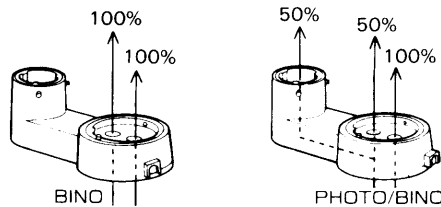

**[P-IBSD]** Set the optical path switching knob to the left or right. Setting it to the left allows you to use only the rear port and setting it to the right, both the rear and side ports.

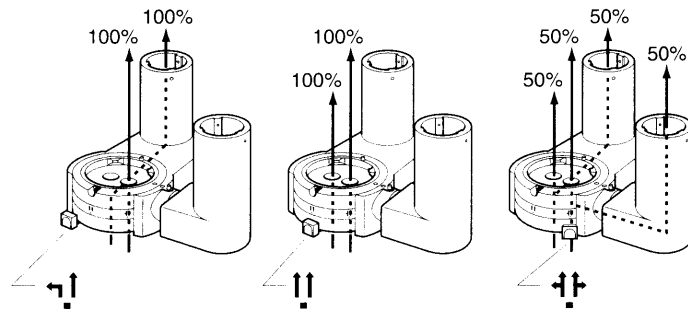

**2 Focusing**

The following is the focusing procedure using the photo reticle. For the focusing procedure using the finder of the photomicrographic equipment, refer to the instruction manual of the photomicrographic equipment.

- 1 Once remove the field ring of the eyepiece and attach the photo mask reticle. (Refer to p.19 "1. Reticles".)
- 2 Turn the diopter ring to focus on the reticle.
- 3 Turn the focus knob to focus on both the reticle and the image.

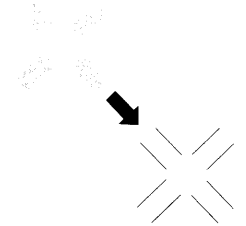

Adjust so that the double crosshairs is clearly divided in two

*Note) [P-IBSD]*

*You can not observe the image through the left eyepiece if the optical path switching knob is set to the left. In this case, use the finder of the photomicrographic equipment for focusing.*

*Focusing with the right eyepiece or focusing with the optical path switching knob set to the position other than left may result in defocusing.*

**3 Adjusting the frame position**

Turn the eyepiece to align each frame of the photo mask and the photomicrographic equipment finder. Note that the image seen through the finder is reversed from that seen through the eyepiece.

**Finder and eyepiece images**

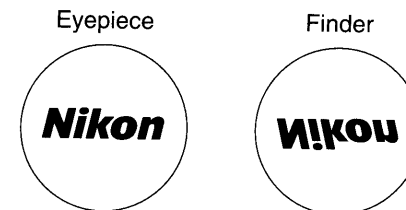

**Table 1: Total Magnification and Real Field**

**SMZ1000**

Objectives	Working distance [mm]	Eyepieces							
		10 X Field number 22 Reticle diameter $\phi 25$		15 X Field number 16 Reticle diameter $\phi 19$		20 X Field number 12.5 Reticle diameter $\phi 19$ Magnification 1.3X		30 X Field number 7 Reticle diameter $\phi 12$ Magnification 1.4X	
		Total magnification	Real field [mm]	Total magnification	Real field [mm]	Total magnification	Real field [mm]	Total magnification	Real field [mm]
Acro 0.5 X	189	4 ~ 40 X	55.0 ~ 5.5	6 ~ 60 X	40.0 ~ 4.0	8 ~ 80 X	31.3 ~ 3.1	12 ~ 120 X	17.5 ~ 1.8
Plan 1 X	78	8 ~ 80 X	27.5 ~ 2.8	12 ~ 120 X	20.0 ~ 2.0	16 ~ 160 X	15.6 ~ 1.6	24 ~ 240 X	8.8 ~ 0.9
Plan 1 X ERGO	50	8 ~ 80 X	27.5 ~ 2.8	12 ~ 120 X	20.0 ~ 2.0	16 ~ 160 X	15.6 ~ 1.6	24 ~ 240 X	8.8 ~ 0.9
Plan Apo 0.5 X	123	4 ~ 40 X	55.0 ~ 5.5	6 ~ 60 X	40.0 ~ 4.0	8 ~ 80 X	31.3 ~ 3.1	12 ~ 120 X	17.5 ~ 1.8
Plan Apo 1 X	70	8 ~ 80 X	27.5 ~ 2.8	12 ~ 120 X	20.0 ~ 2.0	16 ~ 160 X	15.6 ~ 1.6	24 ~ 240 X	8.8 ~ 0.9
ED Plan 1.5 X	44.5	12 ~ 120 X	18.3 ~ 1.8	18 ~ 180 X	13.3 ~ 1.3	24 ~ 240 X	10.4 ~ 1.0	36 ~ 360 X	5.8 ~ 0.6
ED Plan 2 X	32.5	16 ~ 160 X	13.8 ~ 1.4	24 ~ 240 X	10.0 ~ 1.0	32 ~ 320 X	7.8 ~ 0.8	48 ~ 480 X	4.4 ~ 0.4
HR Plan Apo 0.5 X	136	5 ~ 50 X	44.0 ~ 4.4	7.5 ~ 75 X	32.0 ~ 3.2	10 ~ 100 X	25 ~ 2.5	15 ~ 150 X	14 ~ 1.4
HR Plan Apo 1 X	54	10 ~ 100 X	22.0 ~ 2.2	15 ~ 150 X	16.0 ~ 1.6	20 ~ 200 X	12.5 ~ 1.3	30 ~ 300 X	7 ~ 0.7
HR Plan Apo 1.6 X	24	16 ~ 160 X	13.8 ~ 1.4	24 ~ 240 X	10.0 ~ 1.0	32 ~ 320 X	7.8 ~ 0.8	48 ~ 480 X	4.4 ~ 0.4

**SMZ800**

Objectives	Working distance [mm]	Eyepieces							
		10 X Field number 22 Reticle diameter $\phi 25$		15 X Field number 16 Reticle diameter $\phi 19$		20 X Field number 12.5 Reticle diameter $\phi 19$ Magnification 1.3X		30 X Field number 7 Reticle diameter $\phi 12$ Magnification 1.4X	
		Total magnification	Real field [mm]	Total magnification	Real field [mm]	Total magnification	Real field [mm]	Total magnification	Real field [mm]
Acro 0.5 X	189	5.0 ~ 31.5 X	44.0 ~ 7.0	7.5 ~ 47.3 X	32.0 ~ 5.1	10.0 ~ 63.0 X	25.0 ~ 4.0	15.0 ~ 94.5 X	14.0 ~ 2.2
Plan 1 X	78	10.0 ~ 63.0 X	22.0 ~ 3.5	15.0 ~ 94.5 X	16.0 ~ 2.5	20.0 ~ 126.0 X	12.5 ~ 2.0	30.0 ~ 189.0 X	7.0 ~ 1.1
Plan 1 X ERGO	50	10.0 ~ 63.0 X	22.0 ~ 3.5	15.0 ~ 94.5 X	16.0 ~ 2.5	20.0 ~ 126.0 X	12.5 ~ 2.0	30.0 ~ 189.0 X	7.0 ~ 1.1
Plan Apo 0.5 X	123	5.0 ~ 31.5 X	44.0 ~ 7.0	7.5 ~ 47.3 X	32.0 ~ 5.1	10.0 ~ 63.0 X	25.0 ~ 4.0	15.0 ~ 94.5 X	14.0 ~ 2.2
Plan Apo 1 X	70	10.0 ~ 63.0 X	22.0 ~ 3.5	15.0 ~ 94.5 X	16.0 ~ 2.5	20.0 ~ 126.0 X	12.5 ~ 2.0	30.0 ~ 189.0 X	7.0 ~ 1.1
ED Plan 1.5 X	44.5	15.0 ~ 94.5 X	14.7 ~ 2.3	22.5 ~ 141.8 X	10.7 ~ 1.7	30.0 ~ 189.0 X	8.3 ~ 1.3	45.0 ~ 283.5 X	4.7 ~ 0.7
ED Plan 2 X	32.5	20.0 ~ 126.0 X	11.0 ~ 1.7	30.0 ~ 189.0 X	8.0 ~ 1.3	40.0 ~ 252.0 X	6.3 ~ 1.0	60.0 ~ 378.0 X	3.5 ~ 0.6
HR Plan Apo 0.5 X	136	6.3 ~ 39.4 X	35.2 ~ 5.6	9.4 ~ 59.1 X	25.6 ~ 4.1	12.5 ~ 78.8 X	20.0 ~ 3.2	18.8 ~ 118.1 X	11.2 ~ 1.8
HR Plan Apo 1 X	54	12.5 ~ 78.8 X	17.6 ~ 2.8	18.8 ~ 118.1 X	12.8 ~ 2.0	25.0 ~ 157.5 X	10.0 ~ 1.6	37.5 ~ 236.3 X	5.6 ~ 0.9
HR Plan Apo 1.6 X	24	20.0 ~ 126.0 X	11.0 ~ 1.7	30.0 ~ 189.0 X	8.0 ~ 1.3	40.0 ~ 252.0 X	6.3 ~ 1.0	60.0 ~ 378.0 X	3.5 ~ 0.6

**Table 1: Total Magnification and Real Field**

**Table 2: Observable Sample Heights**

**Table 2: Observable Sample Heights [mm]**

**SMZ1000 + C-PS160 + C-FMC**

Objectives	Mount normal position	Mount up side down position	When using C-EP extension pillar	When using SM-S4L and C-EP extension pillar
Acro 0.5X	0 ~ 24	—	0 ~ 124	0 ~ 13
Plan 1X	0 ~ 97	0 ~ 42	0 ~ 197	0 ~ 86
Plan 1X ERGO	0 ~ 114	0 ~ 59	0 ~ 214	0 ~ 103
Plan Apo 0.5X	0 ~ 25	—	0 ~ 125	0 ~ 14
Plan Apo 1X	0 ~ 102	0 ~ 47	0 ~ 202	0 ~ 91
ED Plan 1.5X	0 ~ 111	0 ~ 56	0 ~ 211	0 ~ 100
ED Plan 2X	0 ~ 108	0 ~ 53	0 ~ 208	0 ~ 97
HR Plan Apo 0.5X	0 ~ 33	—	0 ~ 133	0 ~ 22
HR Plan Apo 1X	0 ~ 103	0 ~ 48	0 ~ 203	0 ~ 92
HR Plan Apo 1.6X	0 ~ 112	0 ~ 57	0 ~ 212	0 ~ 101

**SMZ800 + C-PS**

Objectives	Arm normal position	Arm lower position	When using auxiliary adapter	When using SM-S4L and auxiliary adapter
Acro 0.5X	0 ~ 2	—	0 ~ 58	—
Plan 1X	0 ~ 75	0 ~ 20	26 ~ 131	0 ~ 20
Plan 1X ERGO	0 ~ 92	0 ~ 37	3 ~ 148	0 ~ 37
Plan Apo 0.5X	0 ~ 3	—	0 ~ 59	—
Plan Apo 1X	0 ~ 81	0 ~ 26	32 ~ 137	0 ~ 25
ED Plan 1.5X	0 ~ 89	0 ~ 34	40 ~ 145	0 ~ 34
ED Plan 2X	0 ~ 87	0 ~ 32	38 ~ 143	0 ~ 31
HR Plan Apo 0.5X	0 ~ 11	—	0 ~ 67	—
HR Plan Apo 1X	0 ~ 82	0 ~ 27	33 ~ 138	0 ~ 27
HR Plan Apo 1.6X	0 ~ 90	0 ~ 35	41 ~ 146	0 ~ 35

## **NIKON CORPORATION**

9-16, Ohi 3-chome, Shinagawa-ku, Tokyo 140-8505, Japan

**Tel:** +81-3-3773-8121/8122 **Fax:** +81-3-3773-8115

## **NIKON INSTRUMENTS INC.**

1300 Walt Whitman Road, Melville, NY 11747-3064, U.S.A.

**Tel:** +1-516-547-8500 **Fax:** +1-516-547-0306

## **NIKON EUROPE B.V.**

Schipholweg 321, P.O. Box 222, 1170 AE Badhoevedorp, The Netherlands

**Tel:** +31-20-44-96-222 **Fax:** +31-20-44-96-298